

OVERVIEW

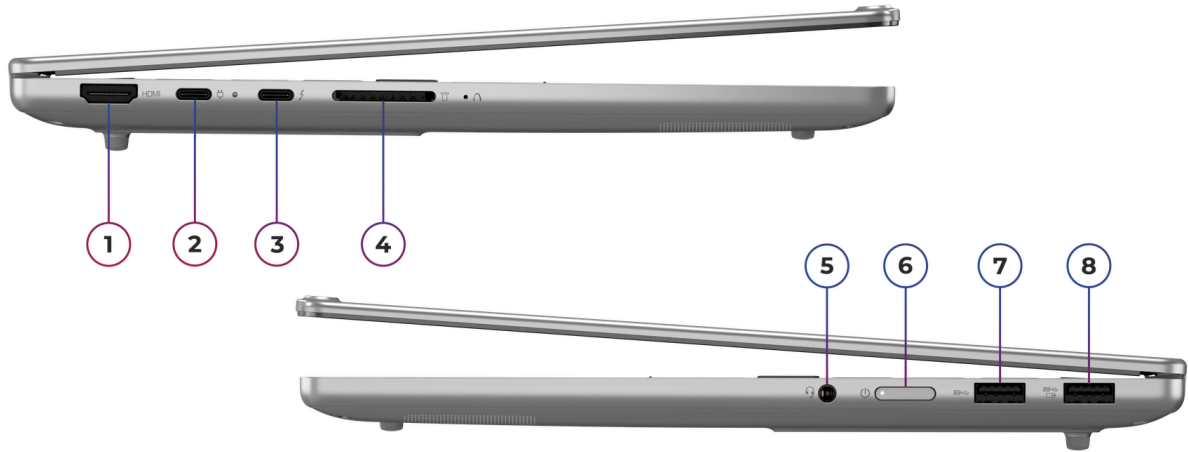

1. HDMI	5. Headphone / microphone combo jack (3.5mm)
2. Thunderbolt 4	6. Power button
3. Thunderbolt 4	7. USB-A (USB 5Gbps)
4. SD card reader	8. USB-A (USB 5Gbps), Always On

PERFORMANCE

Processor

Processor Family

Intel® H Series Core Ultra 5 / 7 / 9 Processor (Series 2)

Processor**

Processor Name	Cores	Threads	Base Frequency	Max Frequency	Cache	Processor Graphics	NPU	Overall TOPS
Core Ultra 5 225H	14 (4 P-core + 8 E-core + 2 LP E-core)	14	P-core 1.7GHz / E-core 1.3GHz / LP E-core 700MHz	P-core 4.9GHz / E-core 4.3GHz / LP E-core 2.5GHz	18MB Intel® Smart Cache	Intel® Arc™ 130T GPU, up to 63 TOPS	Intel® AI Boost, up to 13 TOPS	Up to 83 TOPS
Core Ultra 7 255H	16 (6 P-core + 8 E-core + 2 LP E-core)	16	P-core 2.0GHz / E-core 1.5GHz / LP E-core 700MHz	P-core 5.1GHz / E-core 4.4GHz / LP E-core 2.5GHz	24MB Intel® Smart Cache	Intel® Arc™ 140T GPU, up to 74 TOPS	Intel® AI Boost, up to 13 TOPS	Up to 96 TOPS
Core Ultra 9 285H	16 (6 P-core + 8 E-core + 2 LP E-core)	16	P-core 2.9GHz / E-core 2.7GHz / LP E-core 1GHz	P-core 5.4GHz / E-core 4.5GHz / LP E-core 2.5GHz	24MB Intel® Smart Cache	Intel® Arc™ 140T GPU, up to 77 TOPS	Intel® AI Boost, up to 13 TOPS	Up to 99 TOPS

AI (Artificial Intelligence)

AI PC Category

AI PC^[1]

NPU

Integrated Intel® AI Boost, up to 13 TOPS

Notes:

[1] AI PCs have a NPU capable of 10+ TOPs to run the Copilot assistant by pressing the optional Microsoft® Copilot key or using Win + C.

Operating System

Operating System**

- Windows® 11 Pro
- Windows® 11 Home
- Windows® 11 Home Single Language
- No preload operating system

Graphics

Graphics**

Graphics	Type	Memory	Key Features
Intel® Arc™ 130T GPU	Integrated	Shared	DirectX® 12.2
Intel® Arc™ 140T GPU	Integrated	Shared	DirectX® 12.2

Monitor Support

Monitor Support^[1]

Supports up to 4 independent displays (native display and 3 external monitors via HDMI® and Thunderbolt™)

- HDMI® supports up to 8K@60Hz
- Thunderbolt™ supports up to 8K@60Hz

Notes:

[1] 8K resolution support needs 2 display pipes. That is, simultaneous display number will "-1" when 8K resolution displayed.

Chipset

Chipset

Intel® SoC (System on Chip) platform

Memory

Max Memory

- 24GB soldered memory, not upgradable
- 32GB soldered memory, not upgradable

Memory Slots

Memory soldered to systemboard, no slots, dual-channel

Memory Type

LPDDR5X-8533

Storage

Max Storage Support^{[1][2]}

Up to two drives, 2x M.2 SSD

- M.2 2242 SSD up to 1TB

Storage Slot^[3]

Two M.2 slots

- One M.2 2242 PCIe® 4.0 x4 slot
- One M.2 2280 PCIe® 4.0 x4 slot

Storage Type

Disk Type	Interface	Offering
M.2 2242 SSD	PCIe® NVMe®, PCIe® 4.0 x4	512GB / 1TB

Notes:

[1] The storage capacity supported is based on the test results with current Lenovo® storage offerings.

[2] The system supports dual SSD via two M.2 slots, but Lenovo® offers only one SSD configuration with a second slot for user self-expansion.

[3] The actual data transfer rate of the following PCIe® interface also depends on the capabilities of the connected PCIe® device. The listed values represent theoretical maximums.

PCIe® 3.0 (x2 / x4): 2 GB/s (16 Gbps) / 4 GB/s (32 Gbps);

PCIe® 4.0 (x2 / x4): 4 GB/s (32 Gbps) / 8 GB/s (64 Gbps);

PCIe® 5.0 (x2 / x4): 8 GB/s (64 Gbps) / 16 GB/s (128 Gbps).

Removable Storage

Card Reader

SD card reader

Multi-Media

Audio Chip

High Definition (HD) Audio

Speakers

Stereo speakers, 2W x2, optimized with Dolby Atmos®

Microphone

Dual-microphone array

Camera

FHD 1080p + IR, with privacy shutter, fixed focus, with ToF sensor

Battery

Battery

84Wh Rechargeable Li-ion Battery, supports Rapid Charge Express (get 3 hours of runtime with a 15-minute charge)

Max Battery Life^[1]

Local video (1080p) playback@150nits: 23.8 hr

Notes:

[1] All battery life claims are approximate maximum and based on results using the MobileMark® 2014, MobileMark® 2018, MobileMark® 25, MobileMark® 30, JEITA 2.0, JEITA 3.0, continuous 1080p video playback (with 150nits brightness and default volume level) or Google Power Load Test (PLT) battery-life benchmark tests. Actual battery life will vary depending on many factors such as product configuration and usage, software use, wireless functionality, power management settings, and screen brightness. The maximum capacity of the battery will decrease with time and use.

Power Adapter

Power Adapter^[1]

- 100W USB-C® slim (3-pin) AC adapter, supports PD 3.0, 100-240V, 50-60Hz
- No power adapter

Notes:

[1] AC adapter offerings depend on the country.

DESIGN

Display

Display

Size	Resolution	Touch	Type	Brightness	Surface	Aspect Ratio	Contrast Ratio	Color Gamut	Refresh Rate	Viewing Angle (L/R/U/D)	Key Features
14"	2.8K (2880x1800)	Non-touch	OLED	500nits (typical) / 1100nits (peak)	Glossy	16:10	1,000,000:1	100% DCI-P3	120Hz VRR	85° / 85° / 85° / 85°	DisplayHDR™ True Black 1000

Touchscreen

Non-touch

Screen-to-Body Ratio

90% AAR (active area ratio)

Color Calibration

X-Rite® factory color calibration

Input Device

Pen

No support

Keyboard

6-row, multimedia Fn keys, key travel 1.5mm, Copilot key

Keyboard Backlight

LED backlight

Touchpad

Buttonless glass surface multi-touch touchpad, supports Precision TouchPad (PTP), 80 x 135 mm (3.15 x 5.31 inches)

Mechanical

Dimensions (WxDxH)^[1]

312 x 221 x 15.5 mm (12.28 x 8.7 x 0.61 inches)

Weight^[2]

Starting at 1.39 kg (3.06 lbs)

Case Color

Luna grey

Case Material

Aluminium (top), aluminium (bottom)

Surface Treatment

Aluminium stamping (anodized with sandblasting)

Notes:

[1] The system dimensions may vary depending on configurations.

[2] The system weight is approximate and based on results in Lenovo® lab, which varies depending on the source of component, variance of the distribution of each component, and manufacturing process. It may not be the exact weight for each specific model.

CONNECTIVITY

Network

WLAN + Bluetooth®[1]**

- Wi-Fi® 6, 802.11ax 2x2 Wi-Fi® + Bluetooth® 5.2, M.2 card
- Wi-Fi® 7, 802.11be 2x2 Wi-Fi® + Bluetooth® 5.4, M.2 card

WWAN

No support

Ethernet

No onboard Ethernet

Notes:

[1] Wi-Fi® operation (including Wi-Fi® 6, Wi-Fi® 6E, Wi-Fi® 7, etc.) is subject to the regulatory requirements of each country. Bluetooth® may operate at a lower version than hardware design depending on the factors such as operating system, driver, etc.

Ports^[1]

Standard Ports

- 1x USB-A (USB 5Gbps / USB 3.2 Gen 1)
- 1x USB-A (USB 5Gbps / USB 3.2 Gen 1), Always On
- 2x USB-C® (Thunderbolt™ 4 / USB4® 40Gbps), with USB PD 65-100W and DisplayPort™ 2.1
- 1x HDMI® 2.1, up to 8K/60Hz
- 1x Headphone / microphone combo jack (3.5mm)
- 1x SD card reader

Notes:

[1] The transfer speed of the ports will vary and, depending on many factors, such as the processing speed of the host device, file attributes and other factors related to system configuration and your operating environment, will be slower than theoretical speed.

Docking

Docking

Various docking solutions supported via Thunderbolt™.

For more compatible docking solutions, please visit [Docking for IdeaPad® Pro 5 14IAH10](#)

SECURITY & PRIVACY

Security

Security Chip

Firmware TPM 2.0 integrated in SoC

Fingerprint Reader

No fingerprint reader

BIOS Security

- Administrator password
- Master hard disk password
- Power-on password
- User hard disk password
- User password
- Self-healing BIOS
- More BIOS security features, please visit [BIOS Simulator](#)

Other Security

- Camera privacy shutter
- IR camera for Windows® Hello (facial recognition)

SERVICE

Warranty

Base Warranty**

- 1-year courier or carry-in service
- 1-year courier or carry-in with 2-year system board service (Korea only)
- 2-year (1-yr battery) courier or carry-in service
- 3-year (1-yr battery) courier or carry-in service

ACCESSORIES

Bundled Accessories

Bundled Accessories***^[1]

- Lenovo® 16" Laptop ECO Topload T210 (black)
- Lenovo® WL310 Bluetooth® Silent Mouse (grey)
- None

Notes:

^[1] For more compatible accessory solutions, please visit [Accessories for IdeaPad® Pro 5 14IAH10](#).

OPERATING REQUIREMENTS

Operating Environment

Temperature^[1]

- At altitudes up to 2438 m (8,000 ft)
 - Operating: 5°C to 35°C (41°F to 95°F)
 - Storage: 5°C to 43°C (41°F to 109°F)
- At altitudes above 2438 m (8,000 ft)
 - Maximum temperature when operating under the unpressurized condition: 31.3°C (88°F)

Relative Humidity

- Operating: 8% to 95% at wet-bulb temperature 23°C (73°F)
- Storage and transportation: 5% to 95% at wet-bulb temperature 27°C (81°F)

Altitude

Maximum altitude (without pressurization): 3048 m (10,000 ft)

Notes:

^[1] When you charge the battery, its temperature must be no lower than 10°C (50°F).

CERTIFICATIONS

Green Certifications^[1]

Green Certifications^[2]

- ENERGY STAR® 9.0
- EPEAT™ Gold Registered^[3]
- ErP Lot 6/26
- RoHS compliant

Notes:

^[1] The items listed under the "Green Certifications" section may not only refer to certification but also registration or self-declaration. For ESG & regulatory compliance documents, please visit <https://compliance.lenovo.com>.

^[2] EPEAT™ registration and ENERGY STAR® certification are optional and only available on the models with preloaded

OS. Please visit epeat.net and energystar.gov for more information.

[3] EPEAT™ is registered where applicable, please visit epeat.net for registration status by country.

Other Certifications

Mil-Spec Test

MIL-STD-810H military test passed (21 test items)

Other Certifications

- (Optional) Intel® Evo™ Platform
 - Eyesafe® Certified 2.0
 - TÜV Rheinland® Flicker Free
 - TÜV Rheinland® Low Blue Light (Hardware Solution)
-
- Feature with ** means that only one option listed under the feature can be configured on selected models. Please refer to the model configuration for specific information.
 - Feature with *** means that one or more options listed under the feature can be configured on selected models. Please refer to the model configuration for specific information.
 - Lenovo reserves the right to change specifications or other product information without notice. Lenovo is not responsible for photographic or typographical errors. **LENOVO PROVIDES THIS PUBLICATION "AS IS", WITHOUT WARRANTY OF ANY KIND, EITHER EXPRESS OR IMPLIED, INCLUDING THE IMPLIED WARRANTIES OF MERCHANTABILITY OR FITNESS FOR A PARTICULAR PURPOSE.** Some jurisdictions do not allow disclaimer of express or implied warranties in certain transactions, therefore this disclaimer may not apply to you.
 - The specifications on this page may not be available in all regions, and may be changed or updated without notice.



intel



intel



intel



intel



intel



intel